

# Vorsana TriPhase Filter

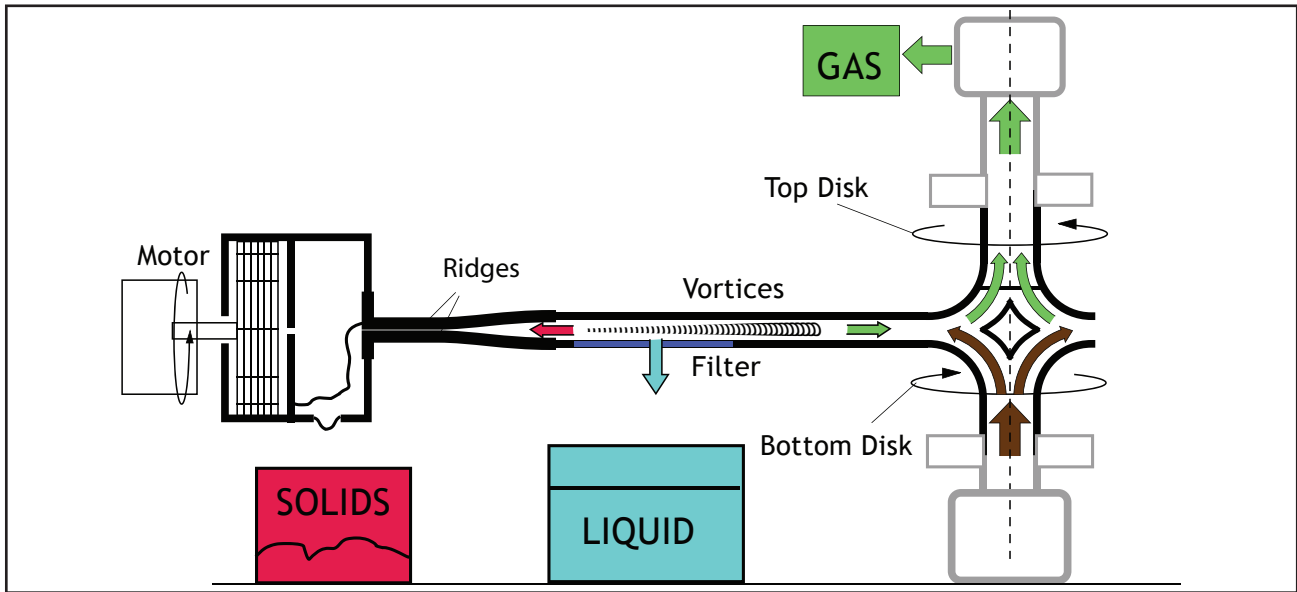

The Vorsana TriPhase Filter continuously separates gases, fluids and solids as it shears and separates a fluid mixture between counter-rotating disk impellers. As the fluid mixture flows outward from the axis, the action of the oppositely rotating disks creates turbulence organized into rapid vortices. A constriction at the disk periphery slows the radially outward flow and increases the residence time of the feed in the working zone. Solids are spun out of the vortices and collect by centrifugation at the impeller periphery, where they thicken into a sludge and are extruded. Fluids exit through an annular crossflow filter, where the shear lift effect ejects solids from the filter surface and keeps the filter clear. The lightest fractions evolve into the cores of the vortices, where they are sucked radially inward and out from between the impellers by an axial pump.

For wastewater treatment, the TriPhase Separator pulls volatiles from the water while filtering out and concentrating solids. It can also be used for dewatering other type of sludge, such as oil sands tailings, which resist other current methods.

US Patent 7757866, Australian Patent 2008340363, Korean Patent 10-1103433.

© 2012 Vorsana, Inc.

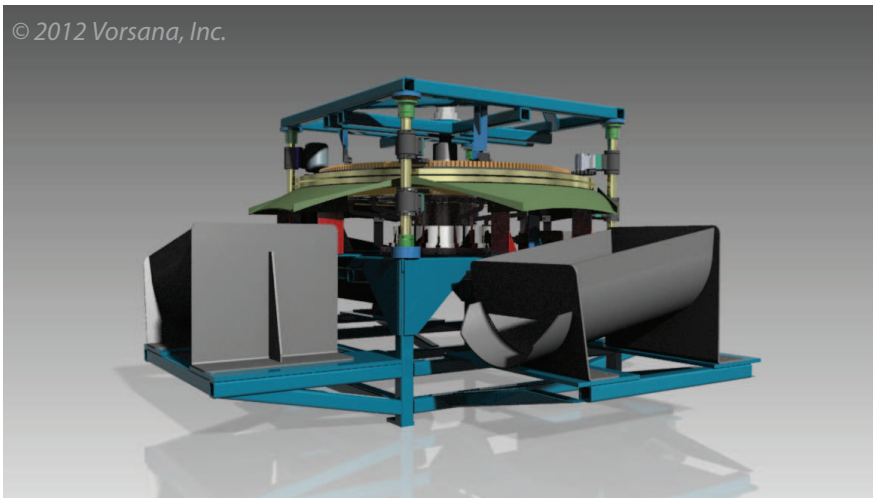

**Vorsana**  
RADIAL COUNTERFLOW SOLUTIONS

[www.vorsana.com](http://www.vorsana.com)

2444 SE Tibbetts St.  
Portland OR 97202  
503 477-4778

contact:  
David McCutchen, CEO  
[david@vorsana.com](mailto:david@vorsana.com)